

Ion - mobility spectrometry based electronic nose - a promising tool for the evaluation of metabolic status of dairy cows

Risto Kauppinen¹, Auvo Sairanen², Teri Hiltunen³, Olavi Raatikainen⁴

¹*Savonia Polytechnic, Agriculture, risto.kauppinen@savonia-amk.fi*

²*MTT Agrifood Research Finland, North Savo, Maaninka, auvo.sairanen@mtt.fi*

³*University of Kuopio, Department of Environmental Sciences, teri.hiltunen@uku.fi*

⁴*University of Kuopio, Food and Health Research Centre, Department of Clinical Nutrition, olavi.raatikainen@uku.fi*

Ketosis is a cattle illness caused by the lack of energy and can be mostly found around peak lactation. Ketosis causes economic losses due to decreased milk production, impaired fertility and increased risk of displaced abomasums. Ketosis is classified clinically and sub-clinically. Sub-clinical ketosis is more deleterious than clinical ketosis.

Ketosis is clinically diagnosed if the milk acetone level in milk sample is more than 50 mg/L. When the acetone level in milk is between 25 - 50 mg/L or the blood beta-hydroxybutyrate (BHBA) is over 1200 micromol/L ketosis status is sub-clinical. However, due to the losses in the milk production, acetone concentration of 14,5 mg/L has been suggested as a threshold value for sub-clinical ketosis (Geishauer et al. 2001). The status of ketosis can be tested in milk by the methods based on the colour changes but they are not precise enough in the case of sub-clinical ketosis.

Ion mobility based spectrometry was applied for the assessment of cow's metabolic status by using the MGD-1 gas detector as an electronic nose. Expiration air and milk samples of those cows preliminarily scored as having clinical or sub-clinical ketosis were measured. Measurements were conducted at MTT Agrifood Research Finland, North-Savo, Maaninka. Five cows calved at the turn of the year were chosen for measuring and treated with nutrition imbalance. Also five reference cows were used for measuring. Measuring was carried out during morning feeding, when cows were given concentrated feed. The cow was tied to the feeding station in a way that it could not remove its head from the feeding station. Each cow was measured for approximately one minute and measuring data was collected to a file. Milk and blood samples were collected from the same cows. Milk samples were analysed with the measuring equipment. Ketone concentration was determined as a reference measuring at the Valio milk laboratory. BHBA and acetoacetate were analysed from the blood samples.

The control cows showed no signs of ketosis. The scoring was made on the basis of milk acetone measurements. The milk samples measured with MGD-1 gas detector based electronic nose can separate the control cows from the cows with ketosis or sub-clinical ketosis ($P < 0,01$, Mann-Whitney U-Test). This indicates that ion mobility technique used in MGD-1 detector provides a basis for a quality control tool for milk production chain. However, much more research and technical development is needed for the development of commercial system suitable for on-line measurement of ketosis from milk of individual cows.

Key Words: dairy cattle, ketosis, subclinical, acetone, beta-hydroxybutyrate, acetoacetate

Introduction

Ketosis is a cattle illness caused by the lack of energy. It is related to milk production and can be mostly found around peak lactation about two months after calving. The large consumption of glucose by the mammary gland leads to a reduction in the glucose concentration in plasma and the body starts to produce glucose mostly from lipids. When lipid metabolism exceeds a certain limit, a concentration of ketone bodies, acetoacetate, beta-hydroxybutyrate (BHBA) and acetone increases in plasma and appear in urine, milk and expiration air as well (Sjaastad et al. 2004). Ketosis causes economic losses due to decreased milk production, impaired fertility and increased risk of displaced abomasums. Ketosis is classified clinically and sub-clinically on the basis of ketone body concentrations in milk and blood. Sub-clinical ketosis is estimated to be more deleterious than clinical ketosis. More than 90 % of the cases occur in the first or second month after calving. During this period on average 40 % of all cows are effected by sub-clinical ketosis once or several times. The prevalence is highest in the first and second week after calving. (Geishauser et al. 2001).

Ketosis status is clinically diagnosed if the milk acetone level in milk sample is more than 50 mg/l. When the acetone level is between 25 - 50 mg/L the ketosis status is sub-clinical. However, due to the losses in the milk production, acetone concentration of 14,5 mg/L has been suggested as a threshold value for sub-clinical ketosis (Geishauer et al, 2001). The status of ketosis can be tested in milk by the methods based on the colour changes but they are not precise enough in the case of sub-clinical ketosis. Subclinical ketosis can be estimated from the blood with BHBA and acetoacetate. Cows are sub-clinically ketotic when their concentration of blood BHBA is over 1200 micro mol/L (Green et al. 1999, Enjalbert et al. 2001). The threshold value of acetoacetate is the concentration of 125 micro mol/L (Enjalbert et al. 2001). The objective of this study was to clarify how MGD-1 gas detector could be applied in indicating ketotic cows on a sufficiently early stage.

Materials and Methods

Ion mobility based spectrometry was applied for the assessment of cow's metabolic status by using the MGD-1 gas detector as an electronic nose. Expiration air and milk samples of those cows preliminarily scored as having clinical or sub-clinical ketosis were measured.

Pilot study

The pilot study was conducted before the actual experiment by measuring acetone-water and acetone-milk mixtures (Figure 1). In this pilot test measuring gas detector's sensibility to acetone was tested. At the first stage acetone mixed with water was used. Acetone concentrations varied between 60– 480 µl/l. Same concentrations are found in the milk of ketosis cows. At the second stage acetone mixed with milk was used at same concentrations. In measuring 100 ml of sample was in a 500 ml lidded glass container. The gas detector sucks the measured gas through valve structure. Headspace-measuring lasted for 40 seconds. A sample was taken at 30-35 seconds from the start of the measuring for processing of measuring results. After measuring, gas was returned back to the container through the same valve structure. This prevents the measured gas from diluting. In between the measuring the gas detector sucks cleared indoor air with activated carbon filter (ACF). "A smell map" is shown in figure 2, where it can be seen how different concentrations differed from each other (Principal Component Analyse, PCA).

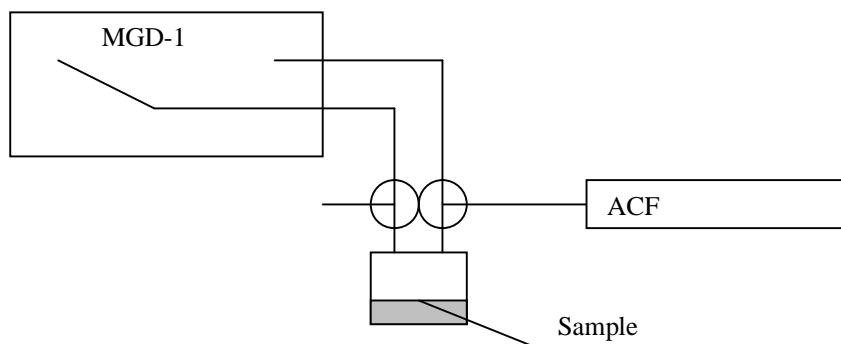

Figure 1. Measuring the headspace sample.

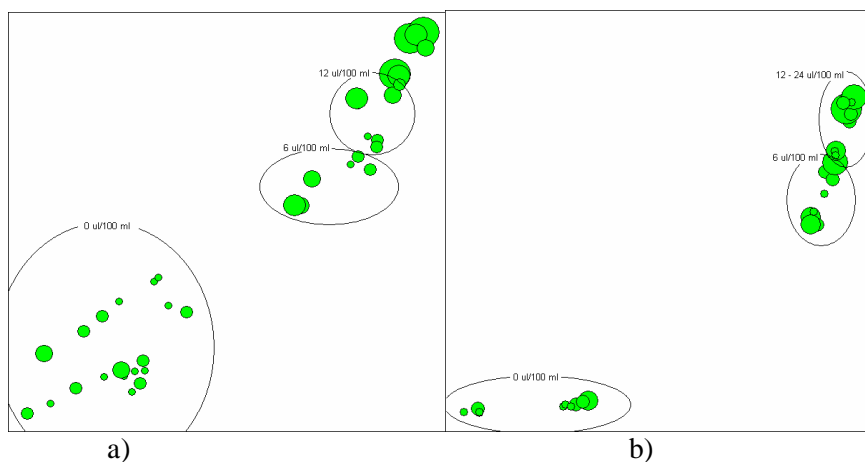

Figure 2. “A smell map” (PCA), acetone mixed with water a) and milk b).

Expiration and milk measuring

Measuring were conducted on 15.-23.1.2002 at MTT Agrifood Research Finland, North-Savo, Maaninka. Five cows that had calved at the turn of the year (calving 49 days before measuring) were chosen for measuring and they were treated with slightly limited feed intake (group K). Also five reference cows (group R) were used for measuring. Total energy intake in group K was 20 MJ lower compared with control group (R).

Expiration air measuring was carried out 21.1. during morning feeding, when cows were given concentrated feed. The cow was tied to the feeding station in a way that it could not remove its head from the feeding station (Figure 3). Upper side of the feeding station was shut with a plywood board during the measuring. After the first measuring time gas's drainage was added to the measuring system. Measured gas was drained using CaCl H₂O in 1000 ml gas washing bottle. Each cow was measured for approximately one minute and measuring data was collected to a file. Milk samples were collected from the same cows and were analysed with the measuring equipment. Ketone concentration was determined as a reference measuring at the Valio milk laboratory (Figure 4) and with a speed test at the research barn. Blood samples were collected a day after the last measurement. BHBA and acetoacetate were analysed (Table 1) at the Central Laboratory of Veterinary Faculty, University of Helsinki.

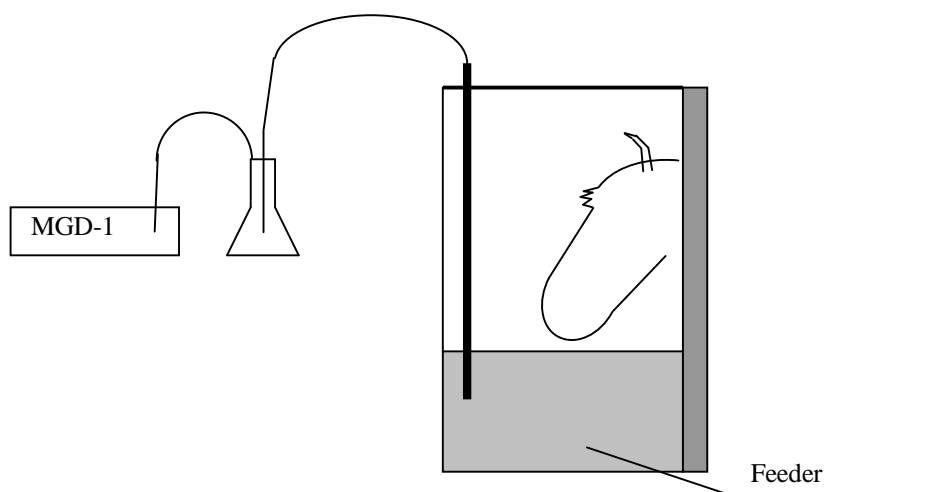

Figure 3. Measuring system when measuring cow's expiration air.

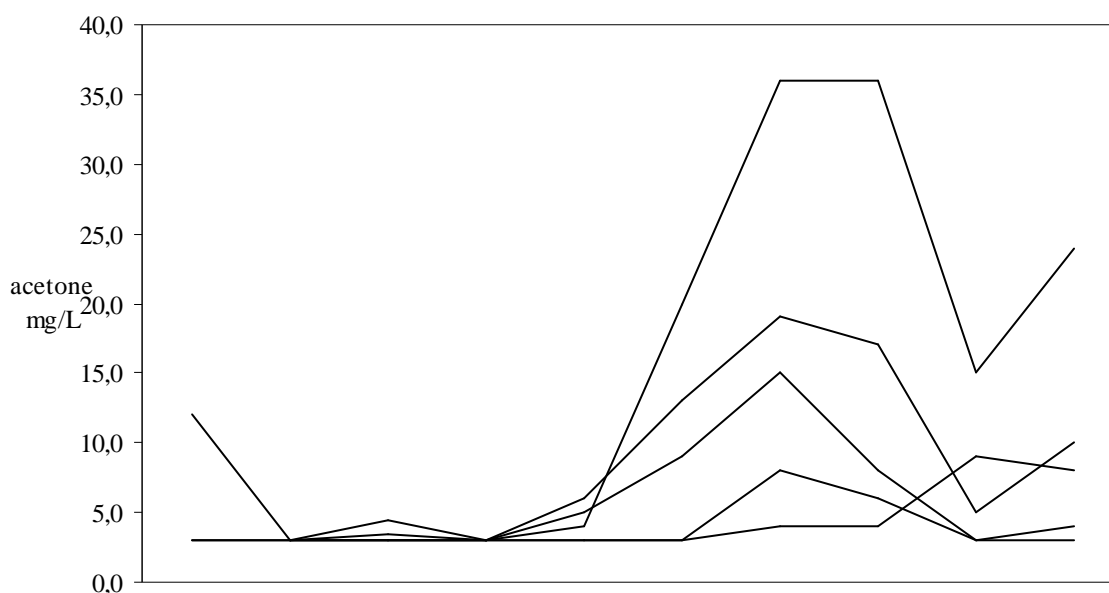

Figure 4. Milk acetone concentrations (mg/L) of the single cows treated with nutrition imbalance between 03.01. – 21.01.2002 (group K).

Table 1. Concentration of BHBA and acetoacetate in blood (mmol/L) and the sum of MGD-1 channel values measured from milk samples in cow group K and R.

	Group K		Group R		Significance
	Mean	SEM	Mean	SEM	
BHBA	1,87	0,30	0,74	0,07	**
Acetoacetate	0,36	0,09	0,07	0,01	*
Sum of MGD-1 channel values,	121,69	9,25	85,85	3,55	**

* P<0,05; ** P<0,01, Mann-Whitney U-Test

Results

There was a significant difference in BHBA concentrations ($P<0,01$) and acetoacetate concentrations ($P<0,05$) between the groups (Table 1)

The sum of MGD-1 channel values measured from milk samples correlated highly with blood BHBA and acetoacetate concentrations ($r=0,88$, $P=0,001$; $r=0,93$, $P<0,001$, respectively). The results of MGD-1 measuring indicate that there was a significant difference ($P<0,01$, Mann-Whitney U-Test) between the test group K with high concentration of BHBA and acetoacetate compared with the group R that had low concentration of BHBA and acetoacetate (Table 1).

No MGD-1 interdependence was found between expiration measuring and the concentrations of ketone bodies. It might be that background air affects the measuring equipment.

Conclusion

The control cows showed no signs of ketosis. The scoring was made on the basis of milk acetone measurements. The milk samples measured with MGD-1 gas detector based electronic nose can separate the control cows from the cows with ketosis or sub-clinical ketosis. This indicates that ion mobility technique used in MGD-1 detector provides a basis for a quality control tool for milk production chain.

However, much more research and technical development is needed for the development of commercial system suitable for on-line measurement of ketosis from milk of individual cows.

References

- Enjalbert, F., Nicot, M-C., Bayourthe, C., Moncoulon, R.** 2001. Ketone bodies in milk and blood of dairy cows: relationship between concentrations and utilization for detection of subclinical ketosis. *Journal of Dairy Science*. 84 (3): 583 – 589.
- Geishauser, T., Leslie, K., Kelton, D., Duffield, T.** 2000. Does monitoring for ketosis in dairy herds pay? *Praktische – Tierarzt*. 81(10): 850 – 858. Hannover, Germany.
- Green, B-L., McBride, B-W., Sandals, D., Leslie, K-E., Bagg, R., Dick, P.** 1999. The impact of monensin controlled-release capsule on subclinical ketosis in the transition dairy cow. *Journal of Dairy Science*. 82 (2): 333 – 342.
- Sjaastad, Ø., Hove, K., Sand, O.** 2004. Metabolism of carbohydrates, proteins, and lipids. In: *Physiology of domestic animals*. ss. 574 – 576.